

Motor Circuit Analysis Concept and Principle

Howard W Penrose, Ph.D.
General Manager, ALL-TEST Pro
Old Saybrook, CT

Abstract

Low voltage Motor Circuit Analysis (MCA) techniques involve the collection and analysis of resistance, impedance, inductance, phase angle, current/frequency response and insulation to ground faults. Output voltage of the test instruments are less than 9 Vac, sinusoidal output. The resulting low level alternating magnetic fields excite the dielectric dipoles and surrounding magnetic steel dipoles, in both the stator and rotor. Winding defects, including developing shorts, cause changes to the dielectric and resulting dipolar 'spin,' which changes the capacitance of the winding circuit at the point of defect. The resulting change effects the phase angle and current/frequency response in the corresponding phase, causing a difference when comparing phase, or coil grouping, to phase. As the defect progresses, the changes to the insulation system continue, allowing trending of the defect over time. The purpose of this paper is to cover the concepts and principles in the physical changes to the windings in winding short and winding contamination faults.

Introduction

Motor Circuit Analysis (MCA) techniques utilizing resistance, impedance, inductance, phase angle, current/frequency response and insulation resistance have been in practice since 1985. The technique has been successfully applied for the detection of winding defects (shorts, resistive unbalances and insulation to ground), cable defects and rotor defects. It has also been found to be able to trend and estimate winding failures with a high degree of accuracy.^{1,2}

In this paper we will discuss the physical properties that allow for the detection of these motor electrical circuit faults using MCA.

The Motor Circuit

Figure 1: Equivalent Circuit One Phase

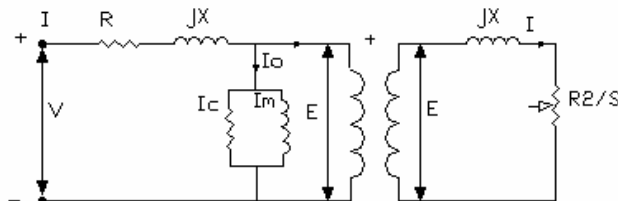

¹ Penrose, Howard W Ph.D., "Estimating Motor Life Using Motor Circuit Analysis Predictive Measurements Part 1," ReliabilityWeb.com, 2004

² Penrose, Howard W Ph.D., "Estimating Motor Life Using Motor Circuit Analysis Predictive Measurements Part 2," ReliabilityWeb.com, 2004

The three phases of an electric motor are separated by 120° electrical. The supply voltage phases are also, optimally, separated by 120° electrical. Within each phase, as the voltage increases, current increases due to the impedance of the motor circuit (see Figure 1). As the current increases, the two magnetic poles increase (or sets of poles), then decrease as current decreases. The stator backiron acts to strengthen and direct the magnetic fields within the airgap between the stator and rotor. As the fields pass through the rotor bars (conductors) of the rotor, a second current develops in the rotor which interacts with the rotating fields in the air gap. The rotor follows the rotating fields, although lags behind the synchronous speed of the stator (slip) in order to maintain a rotor current, and resulting rotor magnetic fields.

As this is occurring, changes also occur to the insulation system and backiron steel. As the current increases in each phase:

- ✓ There is a skin effect within the copper conductors that forces more current towards the surface of the conductor.
- ✓ Insulation dipoles line up between conductors as the phase voltage and current increases then decreases, causing constantly changing capacitance within the circuit between conductors.
- ✓ Insulation dipoles line up between conductors and ground as the phase voltage and current increases then decreases, causing constantly changing capacitance between the winding circuit and ground.
- ✓ Magnetic dipoles line up in the area of effect of each pole within the stator core steel. The reluctance to change in direction is termed as hysteresis.

Operating voltages force the changes to occur fairly rapidly. Changes to the circuit, or to the dielectric or magnetic properties of the motor effect its operation and the force of the operating voltage causes the defective areas of the insulation or steel to heat. Continued breakdown of the dielectric occurs based upon the severity of the fault.

Insulation and Magnetic Field Effects

Figure 2: Insulation Model of Motor Winding System

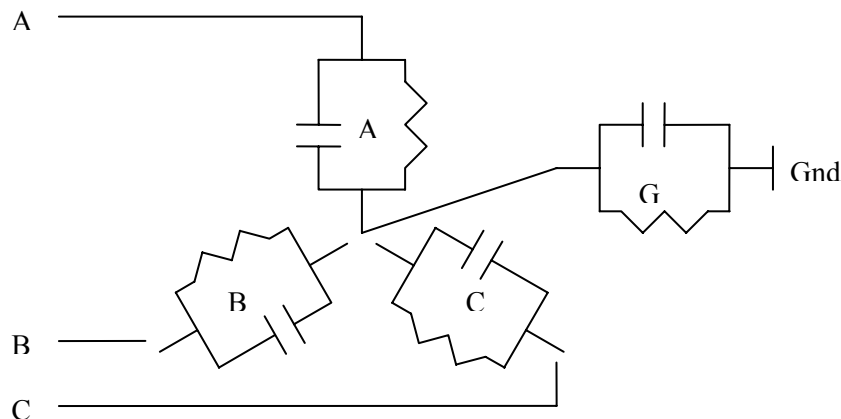

The electrical insulation circuit is modeled as a series of RC circuits between conductors and conductors and conductors and ground. As changes occur to the insulation system, the values of R and C change. The values of A, B, C, in Figure 2, are the sum of the turn to turn and coil to coil RC values of each phase. G is the sum of the insulation between the windings and ground for the complete circuit.

Figure 3: Dipolar Effect of Insulation

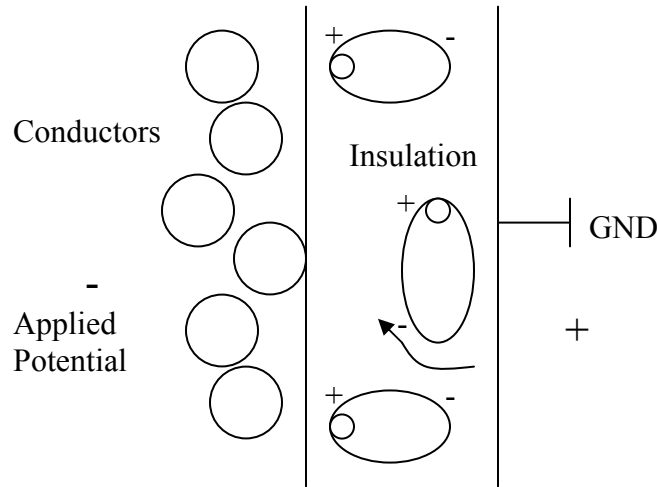

As current passes through conductors near electrical insulation, the insulation reacts by polarizing the atoms (dipoles) within the insulation. As the dipoles line up, there is less leakage (capacitance) between the conductors and ground. This also occurs in the insulation system between conductors when there is a difference of potential. In a good insulation system, the polarization of the insulation happens quickly. Once the potential is removed, the dipoles oppose each other and randomize.

Figure 4: Magnetic Dipoles

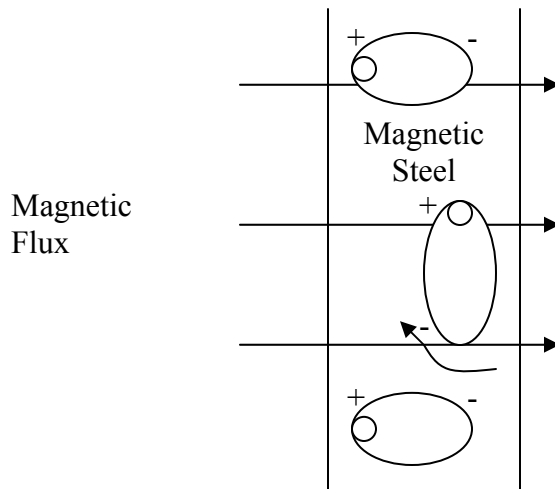

The same effect occurs in a magnetic field. The magnetic dipoles of the backiron and teeth of the stator core line up in the direction of the magnetic field. This helps direct the magnetic flux and adds to the strength of the fields within the airgap. The reluctance of the steel to change polarity shows up as hysteresis losses from the steel. Once the field is removed, the magnetic dipoles of the steel quickly randomize.

The above descriptions for the polarization of electrical insulation and core steel represent the steady-state application of an applied voltage potential. In an operating three phase system, the effects get far more exciting. As each sinusoidal phase of voltage is impressed across the windings:

- ✓ As the voltage starts from zero, the beginning of the coil energizes, the insulating dipoles between the insulation to ground and the conductors within the coil are forced to line up.
- ✓ As the voltage continues to rise, the potential at the beginning of the coil is higher than the end of the coil, insulating dipoles continue to line up and the magnetic dipoles begin to line up in the direction of magnetic flux generated by the coils.
- ✓ As the voltage hits its peak at the beginning of the coil, a majority of the magnetic and insulating dipoles associated with the start of the coil have aligned and the ones at the end of the coil continue to align. There is a lag in the fields between the beginning and end of the coil, which causes a potential between conductors to exist.
- ✓ As the voltage begins to decrease, the insulating and magnetic dipoles begin to randomize at the beginning of the coil and release energy back into the system as the fields collapse. The fields at the end of the coil hit their peak then start to decrease.
- ✓ The voltage approaches zero, then passes into the negative sequence of the sine wave. The dipoles and fields continue to react, but align in the opposite direction. The result is a 'dipolar spin' of both the electrical insulation and magnetic steel dipoles.

The high potential of most electric motors force the changes to the fields and dipoles to happen quickly. As a result, work is performed and heat is generated.

The Capacitance of each portion of the circuit is given, at any time, as:

$$\frac{Q}{Q-q} \frac{\epsilon^{\circ} S}{l} = C$$

Where an insulator exists between the conductors and conductors and ground. The induced charge, q , increases the capacitance by the ratio $Q/(Q-q)$. The dimensionless ratio $q/(Q-q)$ is a property of the polarizability of the material and is referred to as the electric susceptibility, X_e .³ At the boundary of each insulation system (conductors, slot, phase, etc.), the boundary conditions are such that

$$\tan \theta_2 = \epsilon_r \tan \theta_1$$

Where ϵ_r represents the relative permittivity of the boundary of the insulation surface.

³ P. Hammond and J.K. Sykulski, Engineering Electromagnetism: Physical Processes and Computation, Oxford Science Publications, 1994.

By dividing each phase into tubes and slices⁴, the total Capacitance for m slices and n tubes through the system would be

$$C = \sum_1^n \left(\sum_1^m \frac{\delta l}{\epsilon \delta S} \right)^{-1}$$

The inductance of the circuit can be figured as the flux linkage per unit of current:

$$L = \frac{N\phi}{i}$$

and is represented by the unit henry (H).

For a motor with n coils, the inductance may be defined

$$L_{pq} = \frac{N_p (K_{pq} \phi_q)}{i_q}$$

where K_{pq} is referred to as the coupling coefficient between two coils (p and q). When p and q are equal, the inductance is termed as self-inductance, when unequal it is termed mutual inductance.⁵

The total impedance per phase as viewed from the stator input terminals is given

$$Z_i = R_1 + jX_{l1} + \frac{jX_M \left(\frac{R_2'}{s} + jX_{l2}' \right)}{\frac{R_2'}{s} + j(X_M + X_{l2}')}$$

where X refers to the leakage reactances (capacitive).⁶

In simpler form, impedance can also be viewed as⁷

$$X_L = 2\pi fL = \text{Inductive Reactance}$$

$$X_C = \frac{1}{2\pi fC} = \text{Capacitive Reactance}$$

$$Z = \sqrt{R^2 + (X_L - X_C)^2} = \text{Simplified Circuit Impedance}$$

When looking at a balanced system, a wye circuit would appear as in Figure 5.

⁴ The purpose of the tubes and slices approach, as introduced by Hammond and Sykulski, is to provide a manageable means to look at variances through a system. This is done by taking the system in small chunks referred to tubes and slices.

⁵ Nasar, Electric Machines and Electromechanics, Shaum's Outlines, 1981.

⁶ Mulukutla Sarma, Electric Machines Second Edition, PWS Publishing Company, 1996.

⁷ Penrose, Howard W and Jette, James, "Static Motor Circuit Analysis: An Introduction to Theory and Application," IEEE Electrical Insulation Magazine, July/August 2000, Volume 16 Number 4.

Figure 5: Good Winding Balanced Wye

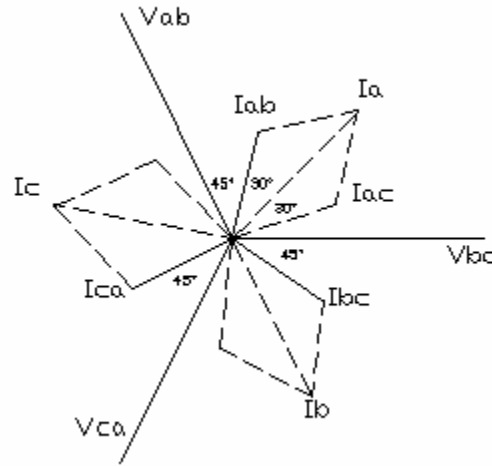

The circuit impedance would appear

$$Z_{AB} = \frac{V_{AB}}{I_{AB}}$$

$$32.9 \angle 45^\circ \Omega = \frac{650.5 \angle 120^\circ V}{19.8 \angle 75^\circ A}$$

Armed with this information, we can now review the effects of winding related faults on the operation of the motor.

Winding Faults

When a defect occurs in a winding due to a developing short, winding contamination or severely damaged core steel, it effects the electrical properties of the insulation system. In the case of a winding defect, changes to either capacitance or resistance will cause a reactive problem due to changes in the makeup of the insulation system. For instance, in a developing short, the changes to the insulation system cause changes to capacitance due to changes in how the dipoles are excited (dipole spin). As a result, there are changes to how the insulation reacts in that area, causing a leakage reactance variance and heating due to forcing the insulation to polarize with higher applied potential. Winding contamination causes changes to the resistive and capacitive reactances between insulating surfaces, as well.

At design voltage, most defects do not become apparent until a distinct change occurs, which may be represented by a severe current unbalance, nuisance tripping or a direct short circuit (smoke). In the case of winding contamination, the end result is the same as a winding short – either a short between conductors or across the insulation system to ground.

As a result, as faults occur due to thermal deterioration (overheating), contamination, moisture absorption or other reactive faults, the circuit impedance will change, slightly, at first, then more dramatic as the fault progresses.

Traditional Test Methods

Most of the traditional test methods require a significant voltage application in order to work. The purpose is to stress the insulation system by forcing a reaction of the insulation dipoles or to force a potential across a resistive or capacitive fault. In this section, we will review a few of the test methods in brief, including: Insulation to ground testing; Polarization Index; Resistance Testing; and, Surge comparison tests.

Insulation to Ground Testing (Meg-Ohm meters)

As described in Figure 3, a DC potential is placed across the motor winding conductors and ground. The applied potential is set and a value of current (leakage) crosses the insulation boundary. This value is converted to resistance, usually in meg-ohms. It is, in effect, a method of measuring leakage across the insulating boundary, but only between the surfaces of the conductors and ground. As the insulation dipoles are only excited with DC, some time is required for them to polarize. Standards normally indicate a winding charging time of about 1 minute and, as insulation resistance is directly effected by temperature and moisture, normalization for temperature.

Polarization Index

The polarization index (PI) test is a measurement of leakage at one minute then at ten minutes. The results are shown as a ratio of the ten minute to one minute reading. It is assumed that a fault will polarize slowly (high ratio) or rapidly (low ratio) due to contamination and changes to the circuit capacitance.

Resistance Testing

Resistance tests use a low voltage DC output and a bridge. The primary purpose is to detect high resistant joints, loose connections, broken connections (or conductors) and direct shorts.

Surge Comparison Testing

An older method of evaluating windings for shorts. A series of steep-fronted higher voltage pulses are sent from the instrument to the stator. The higher voltages force the dipoles in one direction leaving the ability to detect a reactive fault as creating enough potential to cross the barrier (paschens law) either being shut down after partial discharge occurs or an arc is drawn. Both methods of detecting cause a change to the properties of the insulation at the point of defect either accelerating the fault or completing the fault. In order to force slight defects, a greater potential must be applied, stressing the complete

insulation system. Due to the steep fronted pulses, the applied voltage is normally impressed only on the first 2-3 turns in the first coil of each phase.

“The situation is quite different for detecting the breakdown of the turn insulation in a winding (parallel or phase) having many coils. The breakdown of the turn insulation in a single coil in a winding of many coils produces a very small relative change in the characteristics (L, C, R) of total load impedance seen by the surge generator. Hence the change in the VFW [voltage wave form] shape produced by the breakdown of the turn insulation somewhere in a winding of many coils is relatively very small. Hence the surge tests may not reliably verify the presence of one shorted turn in a single phase winding or three phase winding in a machine. The surge tests on windings in a machine may probably lead to wrong conclusions. Perfectly intact windings may appear to have a turn short. More importantly, a turn short induced by the surge test by breaking down the weakened turn insulation may not be detected. In such a case, the stator winding would likely fail after the machine is put back into service.

“In view of the above facts, caution is advised in surge testing of the turn insulation in complete windings. These tests carry very significant risks, which should be carefully considered. Such caution is more important for diagnostic tests on machines in service as such tests are carried out quite infrequently in contrast to frequent tests on new, or refurbished, or repaired machines in a manufacturer’s plant.”⁸

As shown, traditional testing has specific flaws in the ability to detect, and the ability to detect defects in a non-destructive manner.

Modern Low-Voltage Testing: Motor Circuit Analysis

Modern MCA devices use a low voltage sine-wave output designed to excite the insulation system dipoles and surrounding magnetic steel dipoles with low current. There are several key benefits to this approach: Size and voltage rating of the machine being tested do not matter; Specific pass/fail criteria can be applied to phase comparison; and, Degradation can be trended over time without any adverse effects to the existing condition.

“Based upon the physical and electrical properties of coil windings, insulation, systems, transformer theory and electric motor theory, a set of electronic measurements can provide the necessary information to determine the condition of electrical equipment. The measurements must include circuit DC resistance, circuit inductance, circuit impedance, phase angle, current/frequency response tests and insulation resistance readings. Resistance readings are used for open or poor connections, inductance and impedance are used to evaluate winding condition in electric motors and phase balance in all other applications, phase angle and current/frequency response tests evaluate windings

⁸ Bal Gupta, “Risk in Surge Testing of Turn Insulation in Windings of Rotating Machines,” IEEE Electrical Insulation Conference, 2003.

for shorts and insulation resistance readings are used to detect winding to ground shorts.”⁹

Detection of Winding Contamination

Due to the fact that one of the last measurements to change due to a fault is inductance (L), a test result of L can be used as a comparative baseline. This is important as the relative position of the rotor in an assembled machine will effect the reading due to mutual inductance.

$$a^2 = \frac{m_1}{m_2} \left(\frac{k_{w1} N_1}{k_{w2} N_2} \right)^2$$

Where 1 represents the stator winding factors and phases and 2 represents the rotor bar factors and bars per phase. The result is a ratio, the same as a transformer ratio. When a rotor is stationary in an electric motor, the ratios are different for each phase.

Winding contamination causes small changes to the capacitance of the winding circuit. In most cases, the capacitance increases within the circuit. When referencing the simple impedance formula, earlier in this paper, it identifies that an increase in capacitance will have a negative effect on impedance. Also, as the applied voltage is very low, capacitive reactance has a more significant impact on the impedance (Ohms Law) as the capacitive value is more dominant. The result, using a relatively low frequency and sinusoidal output, is a collapse of impedance towards inductance in the phase which has capacitive effects from the contamination or water absorption. In cases of high humidity, the insulation has to have fissures or defects in order to cause the change.

Overheating Windings

Overheated windings have a similar impact as winding contamination. The difference is that the insulation is thermally degrading causing increased resistance to dipolar action. In this case, the capacitance may decrease, causing an increase in impedance in one, or more, phases.

In both winding contamination and overheated windings, the end result would be a winding short. Winding contamination can be corrected if detected in its early stages. However, once changes occur that allow for the detection of a winding fault, the winding will have to be replaced.

Winding Shorts

One of the keys to proper MCA testing is that inductance is not used as a primary method of detection for developing shorts. Instead, two specific measurements are used in combination to determine the type and severity of the defect. These measurements are: The circuit phase angle; and, A Current:Frequency response method.

⁹ Dave Humphrey, Allison Transmission, “Which Road Will You Take,” IEEE Electrical Insulation Conference Proceedings, 2003.

When a defect occurs in the winding, it changes the effective capacitance of the complete circuit. The change to capacitance will directly effect how the low level current lags behind voltage with the usual result being an increase to capacitance and a reduction of the phase angle in the effected phase. Once the fault becomes more severe, it will begin to effect the surrounding phases. This normally occurs when the defect exists in one coil or between coils in the same phase. A very small change to capacitance within the circuit can be detected, allowing the detection of single turn faults and pinhole shorts when using very low frequencies.

A second method of fault detection uses a current ratio, similar in method to the frequency response method used for transformer testing. However, the low voltage current is measured, then the frequency is exactly doubled and a percentage reduction in the low-level current is produced. When the frequency is doubled, small changes to capacitance between turns or between phases are amplified, causing a change to the percentage reduction when compared between phases.

The combination of phase angle and current frequency response allow for the detection of winding shorts and the type of short being detected in any size machine. Also, due to the use of low voltage and the result that only a small change to circuit capacitance is required to detect the faults, early winding defects can be detected quickly and trended to failure.

Additional Tests

In combination with the above tests, MCA utilizes resistance readings and insulation to ground tests. This allows the technology to detect approximately half of the potential faults in the overall motor system and allows for the comparison of any two sets of insulated coils. Faults and defects can be detected in cables, coils, transformers, motors and rotor defects.

Rotor Testing and Back Iron Effects on MCA

The effect of being able to evaluate the condition of the motor rotor is “based upon Faraday’s law of electromagnetic induction, according to which a time-varying flux linking a coil induces an emf (voltage) in it.”¹⁰

$$\begin{aligned}e_1 &= \omega N_1 \phi_m \cos \omega t \text{ for the primary emf} \\e_2 &= \omega N_2 \phi_m \cos \omega t \text{ for the induced secondary emf} \\ \frac{e_1}{e_2} &= \frac{N_1}{N_2} \text{ for the turns ratio} \\ \frac{Z_1}{Z_2} &= \left(\frac{N_1}{N_2}\right)^2 = a^2\end{aligned}$$

¹⁰ Syed A Nasar, Electric Machines and Electromechanics, Schaum’s Outline Series, 1981.

Which is the ratio of the primary and secondary impedances of the circuit.

The motor circuit analyzer excites the core steel based upon the amount of current available to the circuit and reacts across the airgap:

$$nI = \frac{Bl_{iron}}{u_r u_0} + \frac{Bl_{gap}}{u_0}$$

The direct relationship to the ability to detect the rotor across the airgap depends upon the distance across the airgap, the area of the steel magnetized and the length of the stator core. In longer cores, the effect will carry across the airgap and excite the rotor core and induce the instrument frequency into the rotor circuit. In very short cores, the fringing effect of the magnetic field from the stator has a similar effect. In large machines, the amount of energy available from an MCA device allows for the detection of rotor defects only above the area immediately surrounding each coil side.

This produces multiple effects:

1. The mutual inductance changes as the rotor position changes as a direct result of the change to the transformer ratio between the primary (stator) and secondary (rotor). (Reference Figure 1 and Mutual Inductance). A good rotor will show as a repeating pattern, a bad rotor will change the transformer ratio and a defect will appear as a non-repeating pattern.
2. Fractures will be readily detected as the induced energy is relatively low and the oxides on the surface of the defect will change the transformer ratio. Whereas, in higher voltage rotor tests, the energy may be significant enough to pass through the defect.
3. In rare instances, the airgap may be too significant and very little to no variation of the mutual inductance occurs. In this case, larger defects, such as multiple fractures or a broken bar, will show as a variation in the straight line.
4. MCA technology has the ability to detect wound rotor, synchronous rotor field and other wound-rotor defects across the airgap. Because of the impedance ratio between the primary and secondary, rotor winding defects will show as a change to phase angle and current/frequency response and will vary based upon rotor position.

Armature and Commutator Contamination Detection

One of the unique abilities of MCA is the ability to detect carbon buildup in DC motor armatures. Due to the dielectric (capacitive) properties of carbon, capacitance values of the circuit become unstable. This causes test results of impedance, phase angle, current/frequency response and insulation to ground to become unstable and non-repeatable. As a result, armature circuit contamination is detected by noting non-repeatable test results. This is important in that, if detected early, this type of defect may be corrected by blowing out the armature with low pressure air.

Conclusion

Based upon the engineering principles of motor and transformer design, utilizing low voltage test technologies allows for the detection of incipient defects in the electric motor circuit including cable insulation, coils, transformers, connections, motor and rotor windings, armatures, air gap issues and squirrel cage rotor defects, covering over 50% of all potential motor system faults (electrical and mechanical) of any size or voltage machine through the motor circuit and cabling or directly at the machine. This is achieved by utilizing a low potential sinusoidal output (pulsed outputs do not work) from the instrument which excites the insulation and magnetic dipoles of the circuit. The low potential allows defects to become more readily apparent at early stages as it does not force dipolar spin, causing changes to the circuit impedance, phase angle and current at varying frequencies, depending upon the type of fault. These properties of the technology allow for long term trending of developing defects due to insulation breakdown and contamination without any harmful effects on the circuit condition.

About the Author

Dr. Penrose joined ALL-TEST Pro in 1999 following fifteen years in the electrical equipment repair, field service and research and development fields. Starting as an electric motor repair journeyman in the US Navy, Dr. Penrose lead and developed motor system maintenance and management programs within industry for service companies, the US Department of Energy, utilities, states, and many others. Dr. Penrose taught engineering at the University of Illinois at Chicago as an Adjunct Professor of Electrical, Mechanical and Industrial Engineering as well as serving as a Senior Research Engineer at the UIC Energy Resources Center performing energy, reliability, waste stream and production industrial surveys. Dr Penrose has repaired, troubleshot, designed, installed or researched a great many technologies that have been, or will be, introduced into industry. He has coordinated US DOE and Utility projects including the industry-funded modifications to the US Department of Energy's MotorMaster Plus software in 2000 and the development of the Pacific Gas and Electric Motor System Performance Analysis Tool (PAT) project. Dr. Penrose is the Vice-Chair of the Connecticut Section IEEE (institute of electrical and electronics engineers), a past-Chair of the Chicago Section IEEE, Past Chair of the Chicago Section Chapters of the Dielectric and Electrical Insulation Society and Power Electronics Society of IEEE, is a member of the Vibration Institute, Electrical Manufacturing and Coil Winding Association, the International Maintenance Institute, NETA and MENSA. He has numerous articles, books and professional papers published in a number of industrial topics and is a US Department of Energy MotorMaster Certified Professional, as well as a trained vibration analyst, infrared analyst and motor diagnostic specialist.

Bibliography

Sarma, Mulukutla S., Electric Machines: Steady-State Theory and Dynamic Performance, PWS Publishing Company, 1994.

Bodine Electric Company, Small Motor, Gearmotor and Control Handbook, 1993.

Nasar, Syed A., Theory and Problems of Electric Machines and Electromechanics, Schaum's Outline Series, 1981.

Edminster, Joseph, et.al., Electric Circuits Third Edition, Schaums Electronic Tutor, 1997.

Hammond, et.al., Engineering Electromagnetism, Physical Processes and Computation, Oxford Science Publications, 1994.

Penrose, et.al, "Static Motor Circuit Analysis: An Introduction to Theory and Application," IEEE Electrical Insulation Magazine, July/August 2000.

Penrose, Howard W, Ph.D., Motor Circuit Analysis: Theory, Application and Energy Analysis, Success by Design Publishing, 2001

Penrose, Howard W, "Estimating Motor Life Using Motor Circuit Analysis Predictive Measurements," IEEE Electrical Insulation Conference Proceedings, 2003

Stone, et.al, Electrical Insulation for Rotating Machines, IEEE Press Series on Power Engineering, 2004.

Nailen, Richard L, Managing Motors, Second Edition, Barks Publications, 1996.

Fink, et.al., Standard Handbook for Electrical Engineers, Fourteenth Edition, McGraw Hill, 2000.

Humphrey, Dave, "Which Road Will You Take," IEEE Electrical Insulation Conference Proceedings, 2003.

Gupta, Bal, "Risk in Surge Testing of Turn Insulation in Windings of Rotating Machines," IEEE Electrical Insulation Conference Proceedings, 2003.